

FEATURED ALUM-A-LIFT PRECISION CLAMPING LIFT FOR QUARTZ CRUCIBLES

PROJECT 27134

MODEL A800CRSLR-66

FEATURING Auto Leveling Wrists, Powered Precision Clamp, Manual Trunion, Overload/Obstacle Encounter Sensing, Class 1000 Cleanroom Compatibility

HANDLING 220 lb [100 kg] Quartz Crucibles

DETAILS A ceramics manufacturer for semiconductor components needed a lift to handle different size quartz crucibles for loading into a machine. Manual side-to-side rotation allows for precise pouring of the product and for cleaning in between batches. The auto-leveling wrists and obstacle encounter prevent misalignment and damage to the machine when loading. The precision clamp ensures a repeatable clamp force to ensure that excessive force does not damage the crucible.

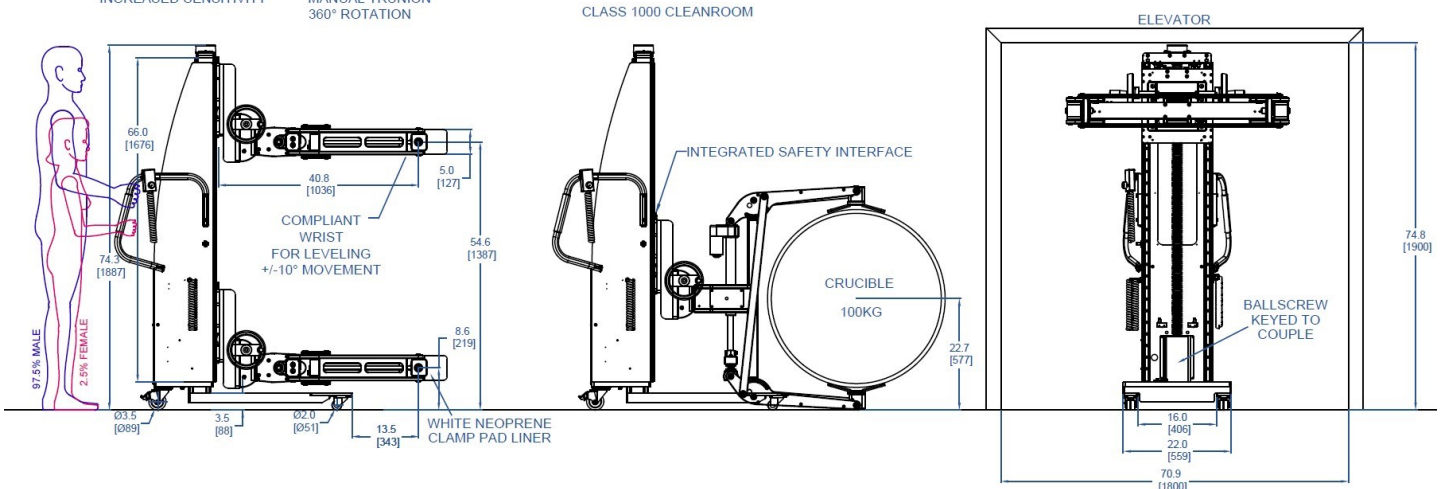
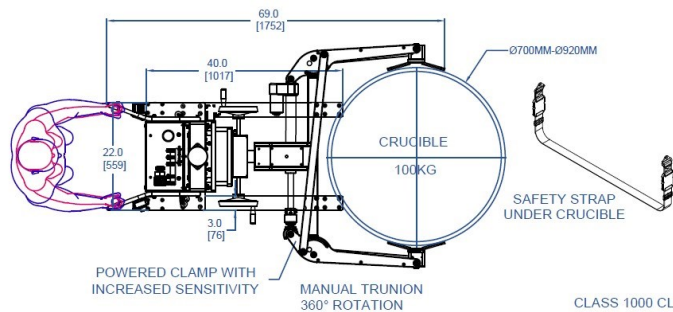

alum-a-lift

13941 Veterans Memorial Hwy
Winston, GA 30187 USA
+1 770 489 0328

GET STARTED AT ALUM-A-LIFT.COM