

FEATURED ALUM-A-LIFT SELF PROPELLED ROLL ROTATOR WITH POWERED CLAMPING

PROJECT 29587



MODEL A1500CSLRPD-72

FEATURING Large Diameter Powered Clamp, Powered Trunion, High Capacity Linear Bearings, Steerable Powered Drive Wheel with Forward/Reverse Melody Alert

HANDLING 441 lb [200 kg] Rolls

DETAILS This Alum-a-Lift is configured to remove large rolls from an unwinder and place them on either a slitting machine or on a pallet for shipment. The lifter's rubber lined clamp pads can grip both full and partial rolls. An adjustable force regulation switch, once dialed in, ensures consistent repeatable clamp force and includes an indicator light for operator feedback. The unit's powered drive wheel make it a compact, user friendly option for situations where a forklift would be considered too large or imprecise.

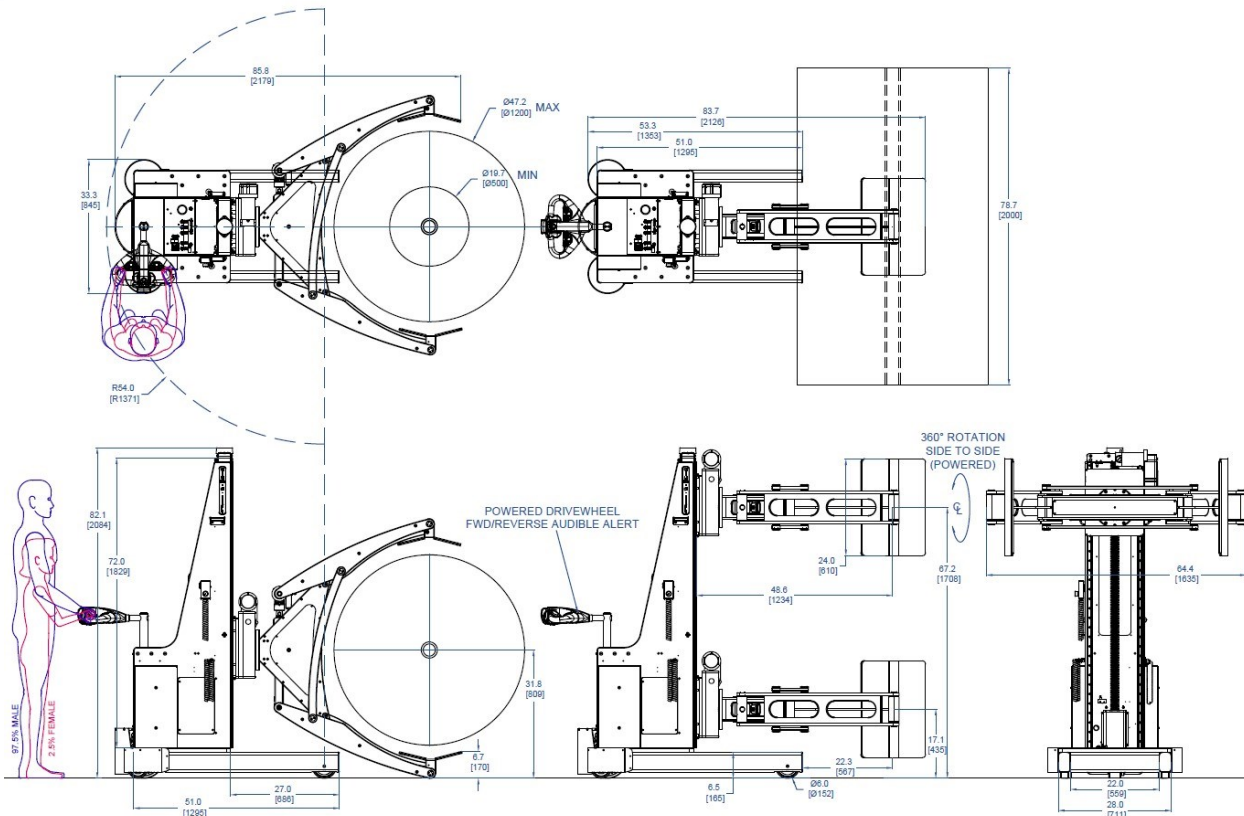

alum-a-lift

13941 Veterans Memorial Hwy
Winston, GA 30187 USA
+1 770 489 0328

GET STARTED AT ALUM-A-LIFT.COM