

FEATURED ALUM-A-LIFT SELF-PROPELLED VACUUM SHEET LIFTER AND ROTATOR

PROJECT 30682

MODEL A3500CSLRPD-108

FEATURING Vacuum Fixture with Individual Suction Cup Compliance, Dual (Redundant) On-Board Vacuum System with Cycle On Demand, Powered Trunion, Powered Shuttle, Steerable Powered Drive Wheel

HANDLING 1000 lb [454 kg] Acrylic Sheets

DETAILS This lift replaced a handful of legacy devices used to handle large stretched acrylic sheets in an aerospace component manufacturing process. This self-sufficient tool includes a vacuum generator, powered lifting, rotation, and side-shift, and a steerable powered drive wheel. It can transport and manipulate components anywhere on the production line and promises to remain a versatile solution for future material handling needs.

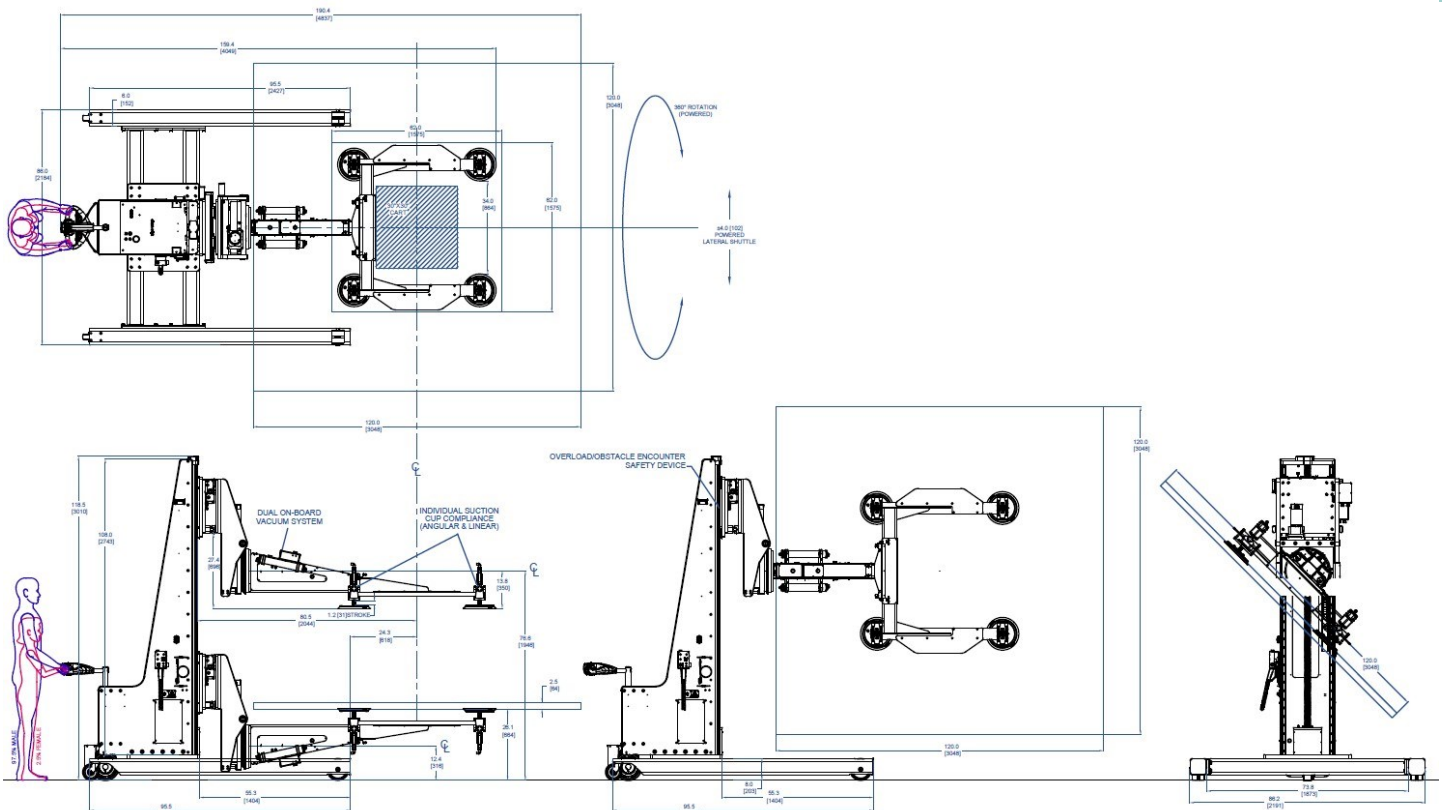

alum-a-lift

13941 Veterans Memorial Hwy
Winston, GA 30187 USA
+1 770 489 0328

GET STARTED AT ALUM-A-LIFT.COM