

FEATURED ALUM-A-LIFT STATIONARY LIFT FOR AEROSPACE WORK POSITIONING

PROJECT 31373



MODEL A1500CSLR-96

FEATURING Quick connect adaptors, high capacity—low backlash powered rotation module, deflection compensation module, traveling limit switch with adjustable stops, and shuttling base

HANDLING 500 lb [226 kg] Optoelectronic Assemblies

DETAILS This lift is used as a test stand to check calibration on completed electromechanical assemblies. The low backlash rotation and deflection modules allows for highly accurate positioning of the component. Quick connect adaptors allow product to be easily loaded and unloaded from the lift without the use of hand tools.

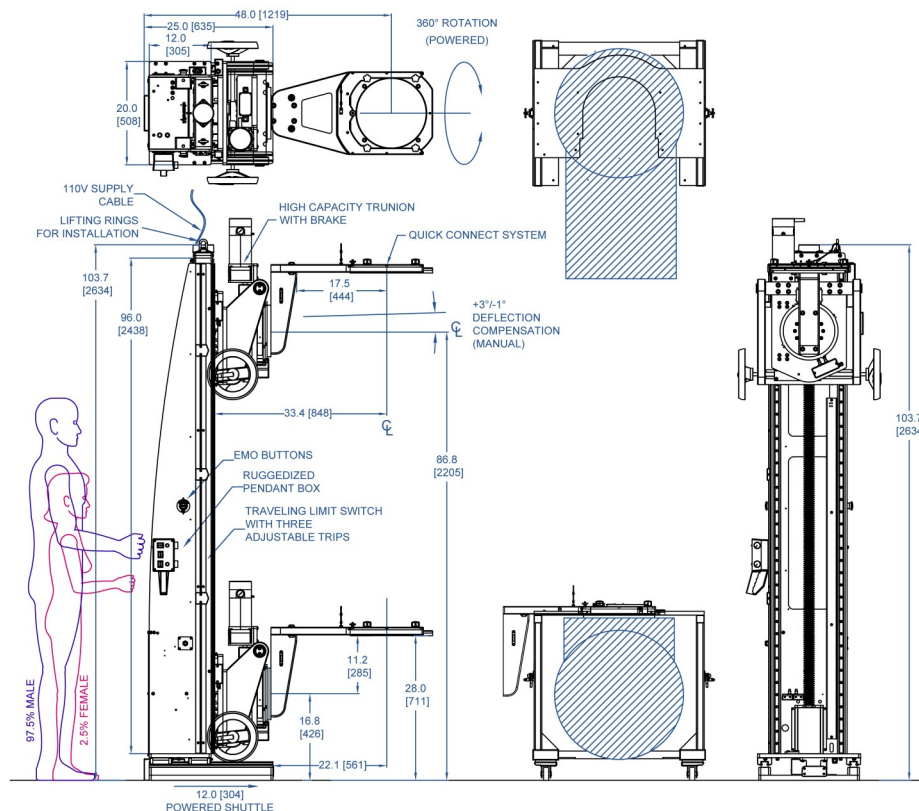

alum-a-lift

13941 Veterans Memorial Hwy
Winston, GA 30187 USA
+1 770 489 0328

GET STARTED AT ALUM-A-LIFT.COM