

# FEATURED ALUM-A-LIFT CLEANROOM CLAMP AND ROTATE DRUM LIFTER

## PROJECT 31572



**MODEL** A1500CRCS-60

**FEATURING** Powered Clamp with Clamp-Force Limiting, Non-Marring Clamp Pads, Powered Rotation Module

**HANDLING** 500 lb [227 kg] Drums

**DETAILS** This Alum-a-Lift was designed to lift and rotate fiber drums within a class 1000 (ISO 6) cleanroom. The lift's powered clamping end-effector securely grips the outside of the drum and a clamp-force limiting feature ensures a consistent grip. A self-locking powered rotation module enables effortless rotation and allows the drum's contents to be dumped in a consistent, controlled manner.

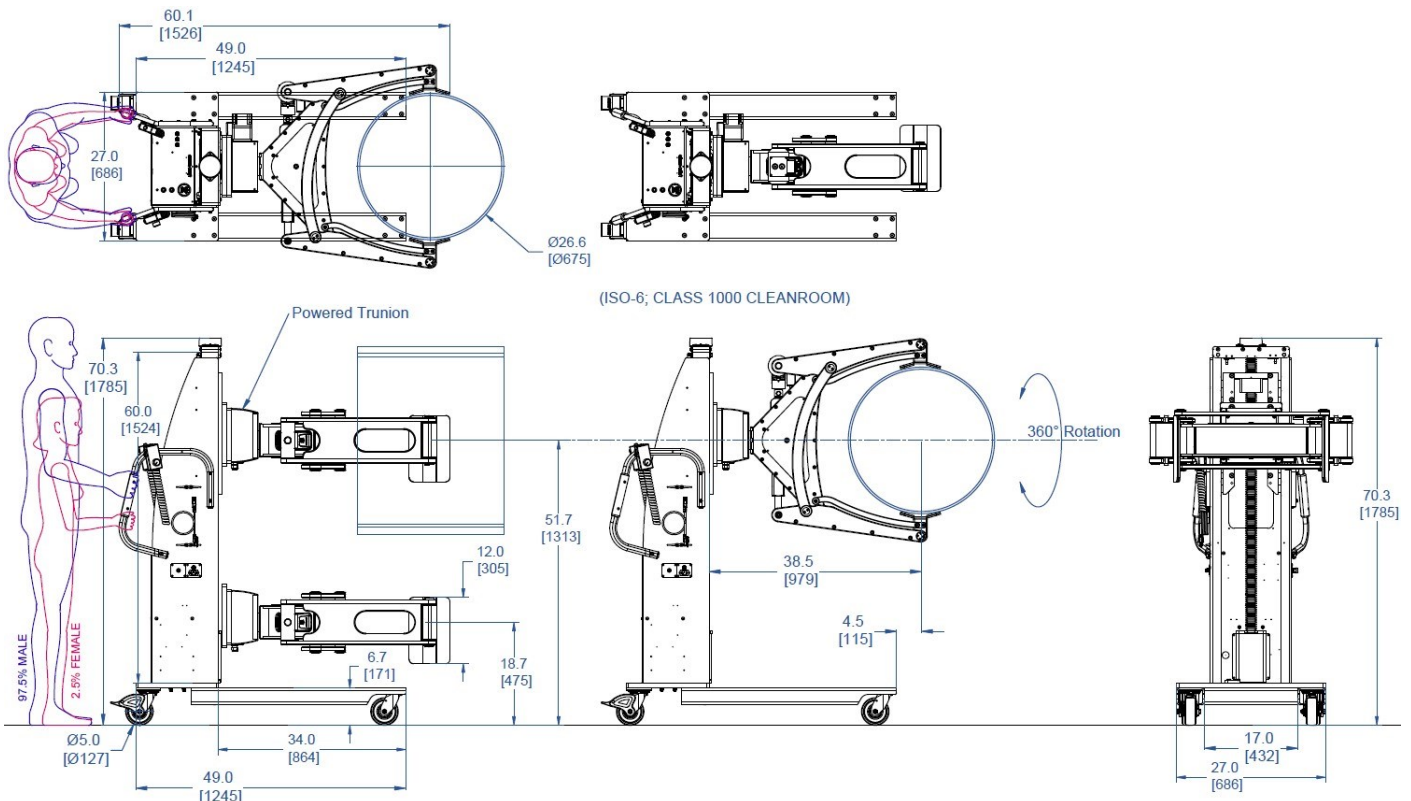

**alum-a-lift**

13941 Veterans Memorial Hwy  
Winston, GA 30187 USA  
+1 770 489 0328

GET STARTED AT [ALUM-A-LIFT.COM](http://ALUM-A-LIFT.COM)