

# FEATURED ALUM-A-LIFT AIRCRAFT PARTS LIFT WITH ROTATING GRIPPER

## PROJECT 31493



**MODEL** A800CSLR-72

**FEATURING** High Friction Pads, Extended Reach Arms, Linear Clamp, Super-duty Rotation Module, Tilt Module

**HANDLING** 300 lb [136 kg] Underwing Aircraft Components

**DETAILS** An aircraft component manufacturer needed a lift to assist with the assembly process for an underwing component. The process included picking and placing the assembly in top-up and bottom-up orientations on carts and storage racks, with each position presenting unique space constraints. This lift uses a linear clamp to securely grip the assembly, and a powered rotation module inverts it as needed. The unique arm arrangement avoids sensitive components on the assembly and fits within standoff blocks on the carts. Due to the length of the assembly, a tilt module is included for deflection compensation.

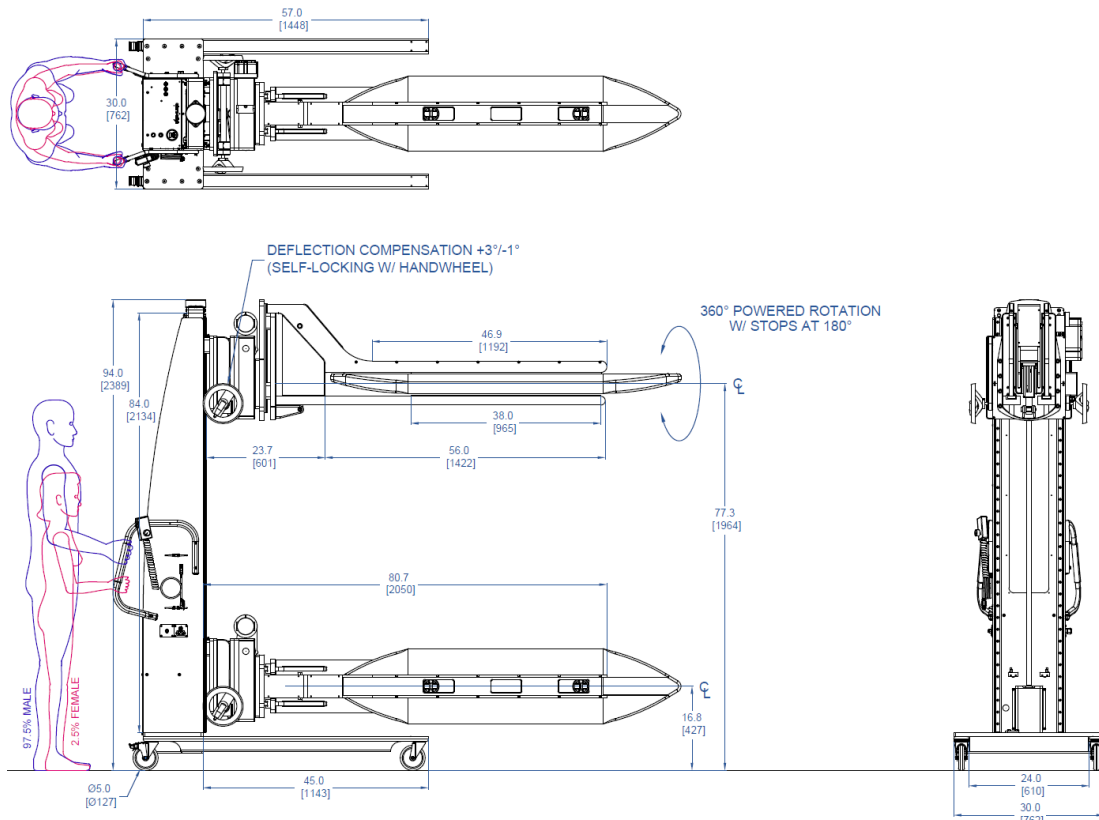

**alum-a-lift**

13941 Veterans Memorial Hwy  
Winston, GA 30187 USA  
+1 770 489 0328

GET STARTED AT [ALUM-A-LIFT.COM](http://ALUM-A-LIFT.COM)