

FEATURED ALUM-A-LIFT SILICON WAFER LIFT FOR SEMICONDUCTOR CLEANROOM

PROJECT 31571

MODEL A800CRSLR-72

FEATURING Pivoting Hooks, Removable Fixture, 360° Swivel, Low Profile Handles, Trapezoidal Base

HANDLING 200 lb. [91 kg] Window Fixtures

DETAILS A semiconductor wafer manufacturer uses this lift to transport fixtured wafers through the stations in their cleaning process, including solvent cleaning tanks, RCA cleaning baths, and deionized (DI) water rinse tanks, all within a Class 10 (ISO 4) Cleanroom. This lift includes hooks that lock into handles on the fixture and allow the fixtured wafers to be lowered into tanks or place on work surfaces. The hooks are mounted on a 360° swivel that allows the fixture to be rotated around the vertical axis for placement in any orientation. A special base design ensures compatibility with all stations in the process.

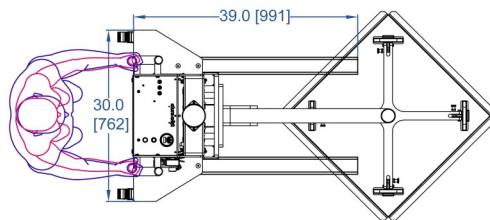

SUITABLE FOR USE IN CLASS 10 CLEANROOM

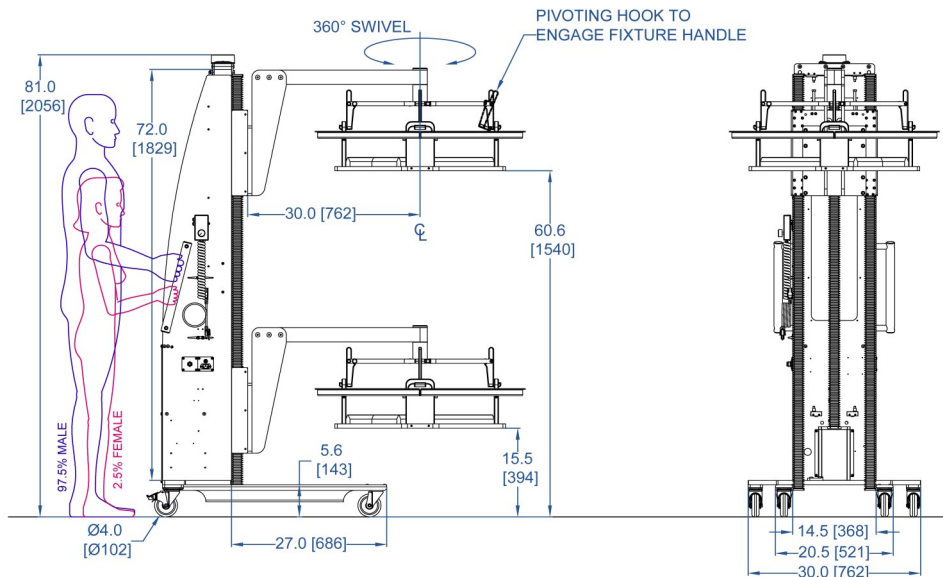

alum-a-lift

13941 Veterans Memorial Hwy
Winston, GA 30187 USA
+1 770 489 0328

GET STARTED AT ALUM-A-LIFT.COM