

# FEATURED ALUM-A-LIFT LIGHTWEIGHT ERGONOMIC ROLL TURNER AND LIFTER

## PROJECT 32281



**MODEL** L200CS-72

**FEATURING** Expanding Mandrel (Short Reach, 3" Cores, 90 degree rotation)

**HANDLING** 55 lb [25 kg] Rolls

**DETAILS** Rolls of paper and plastic are used to package foods, pharmaceuticals, and other consumer products. Using the largest roll that a packaging machine can accept allows the time between changeovers and therefore process output to be maximized. This self-propelled Alum-a-Lift features powered core gripping, lifting, and rotation. A safety light indicator turns on when the system is ready to lift.

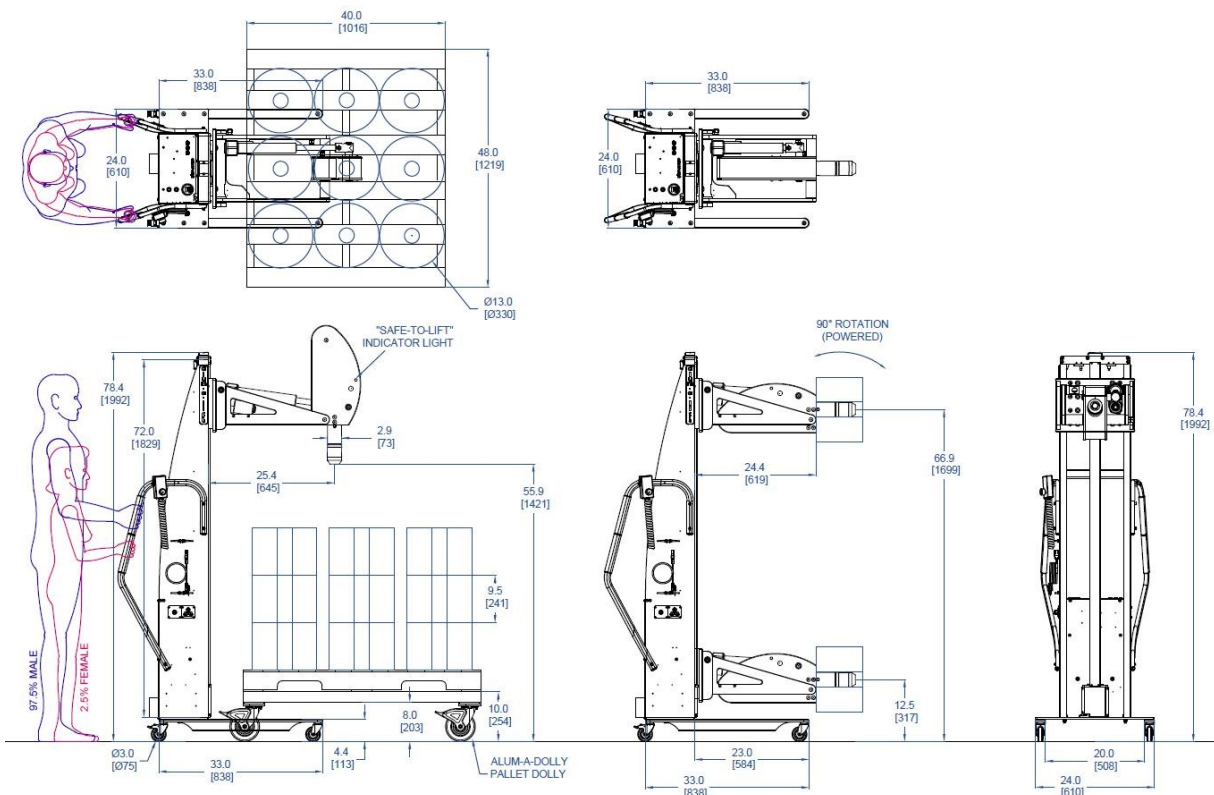

**alum-a-lift**

13941 Veterans Memorial Hwy  
Winston, GA 30187 USA  
+1 770 489 0328

GET STARTED AT [ALUM-A-LIFT.COM](http://ALUM-A-LIFT.COM)