

FEATURED ALUM-A-LIFT INDUSTRIAL KILN LOADER AND CERAMIC STACK TRANSPORTER

PROJECT 32503

MODEL A3500CSLRPD-71

FEATURING Width-adjustable Forks, Vertical Axis Pivot, Lateral Shuttle, Traveling Limit Switch, Low-profile Base

HANDLING 1764 lb. [800 kg] Ceramic Plate Assemblies

DETAILS This lift helps a high-tech manufacturer place large ceramic plate assemblies into industrial kilns. The frame of the assemblies must align precisely with registration features inside the kiln. This lift incorporates large forks to surround the stacks, ensuring that the plates are secure during transit. A lateral shuttle and vertical pivot module combine to allow operators to easily line up the frame with the kiln. A traveling limit switch allows pick and place heights to be pre-set for repeatability, and a low-profile base minimizes the clearance needed beneath the kilns.

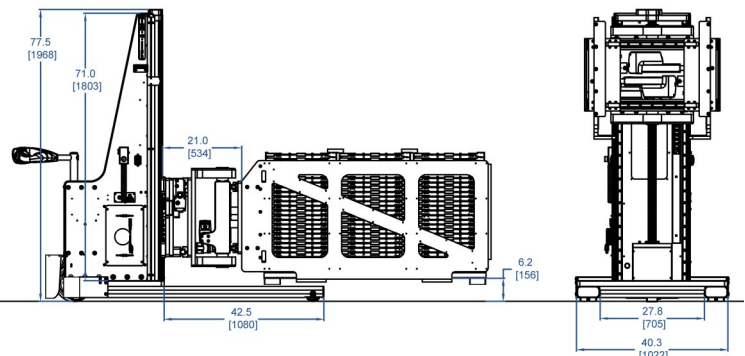
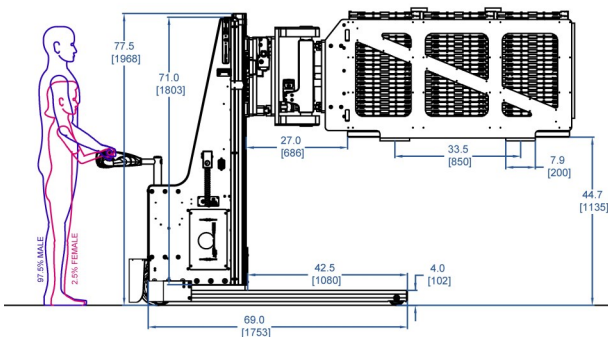
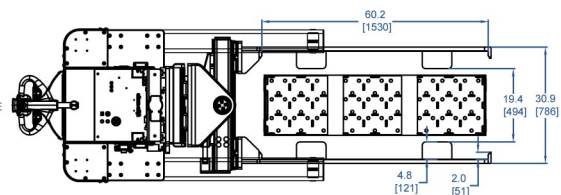
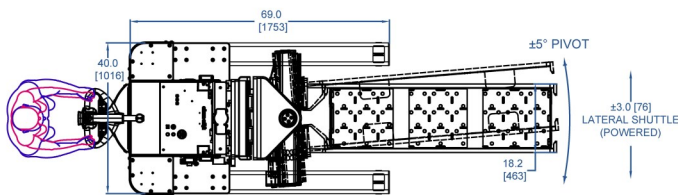
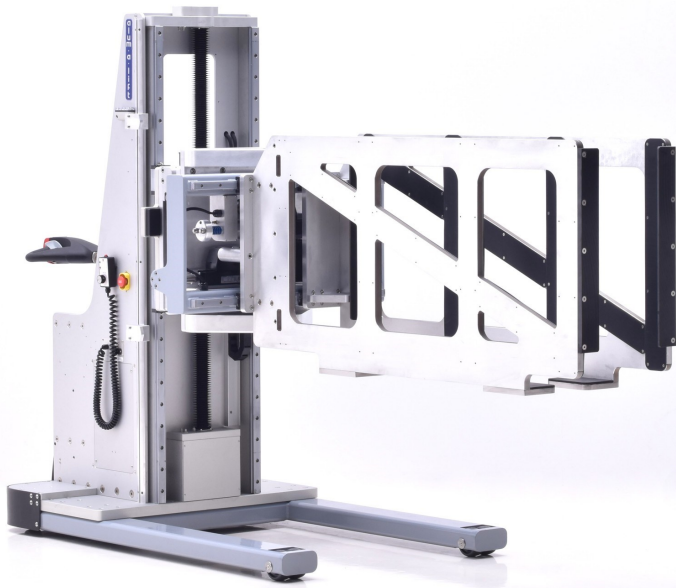

alum-a-lift

13941 Veterans Memorial Hwy
Winston, GA 30187 USA
+1 770 489 0328

GET STARTED AT ALUM-A-LIFT.COM