

FEATURED ALUM-A-LIFT VACUUM WORK POSITIONER LIFT FOR AIRCRAFT GLASS

PROJECT 32481



MODEL A800CS-48

FEATURING Factory Air Powered Vacuum Generator, Swiveling Suction Head, Powered Trunnion, Vacuum Leak Alarm, Powered Safety Arm, Overload/Obstacle-Encounter Sensing

HANDLING 100 lb [45 kg] Aircraft Windshields

DETAILS This Alum-a-Lift allows for edge finishing and framing application on aircraft windshields. The lifter is capable of retrieving and returning pieces from a process conveyor line. A rotating suction head on a powered rotation module allows for windshield glass to be reoriented and lifted to an ergonomic work height, suitable for both seated and standing operators. A powered safety arm and vacuum leak sensor secure the load during use, ensuring a safe work environment.

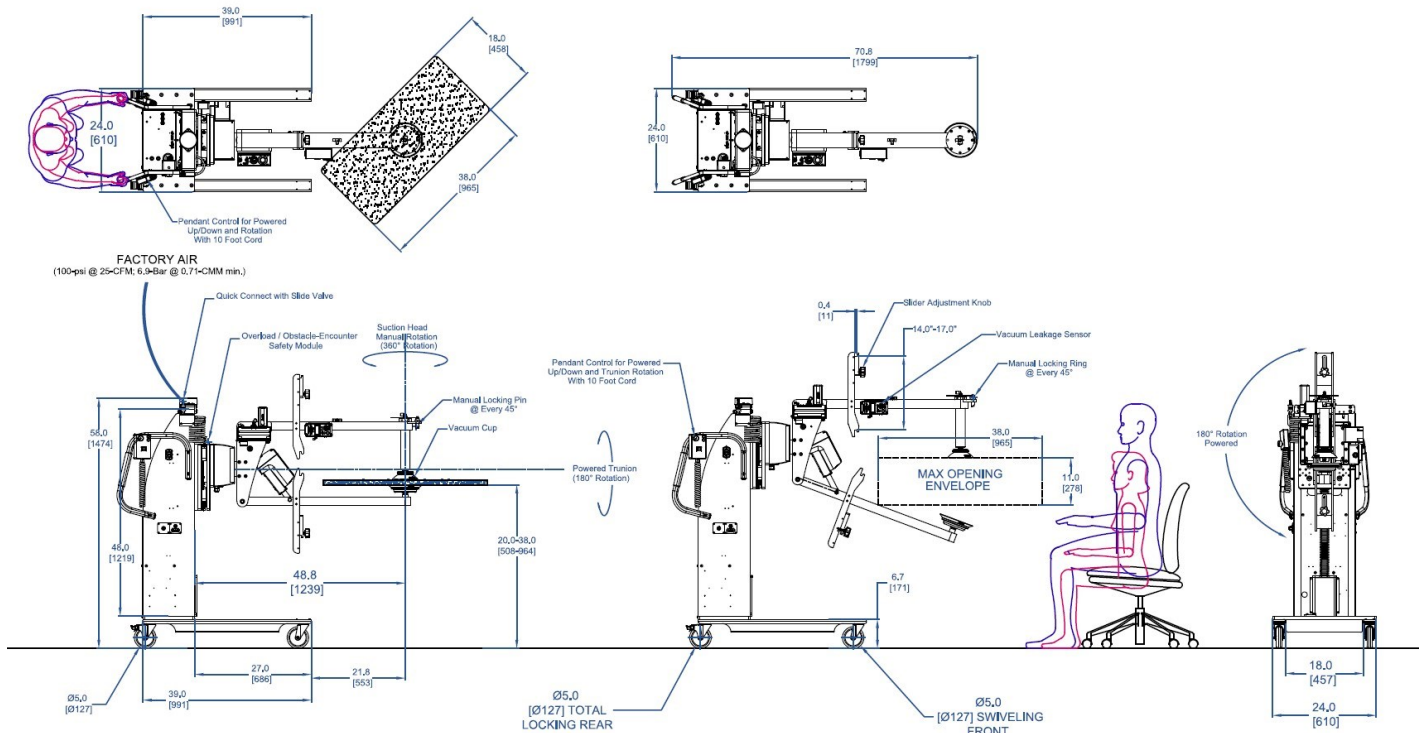

alum-a-lift

13941 Veterans Memorial Hwy
Winston, GA 30187 USA
+1 770 489 0328

GET STARTED AT ALUM-A-LIFT.COM