

FEATURED ALUM-A-LIFT CLEANROOM ROLL HANDLING LIFT WITH V-CRADLE

PROJECT 31653



MODEL A2500CSLRPD-97

FEATURING Steerable Power Drive, Powered Lateral Shuttle, Powered Deflection Compensation, Interchangeable Cradles, ISO 6 (Class 1000) Cleanroom Compatible

HANDLING 800 lb [364 kg] Rolls

DETAILS This lift was designed to load large rolls onto wrapping machines in a clean room with very little space to maneuver. The two interchangeable cradles allow the operator to load rolls onto a cantilevered shaft, or transversely with a thru shaft mounted in the roll. The powered lateral shuttle and powered deflection compensation make for easier targeting when loading and unloading. This lift takes the manual labor out of a task that is otherwise a high risk of injury. The operators were happy to receive a solution to keep them from doing the heavy lifting!

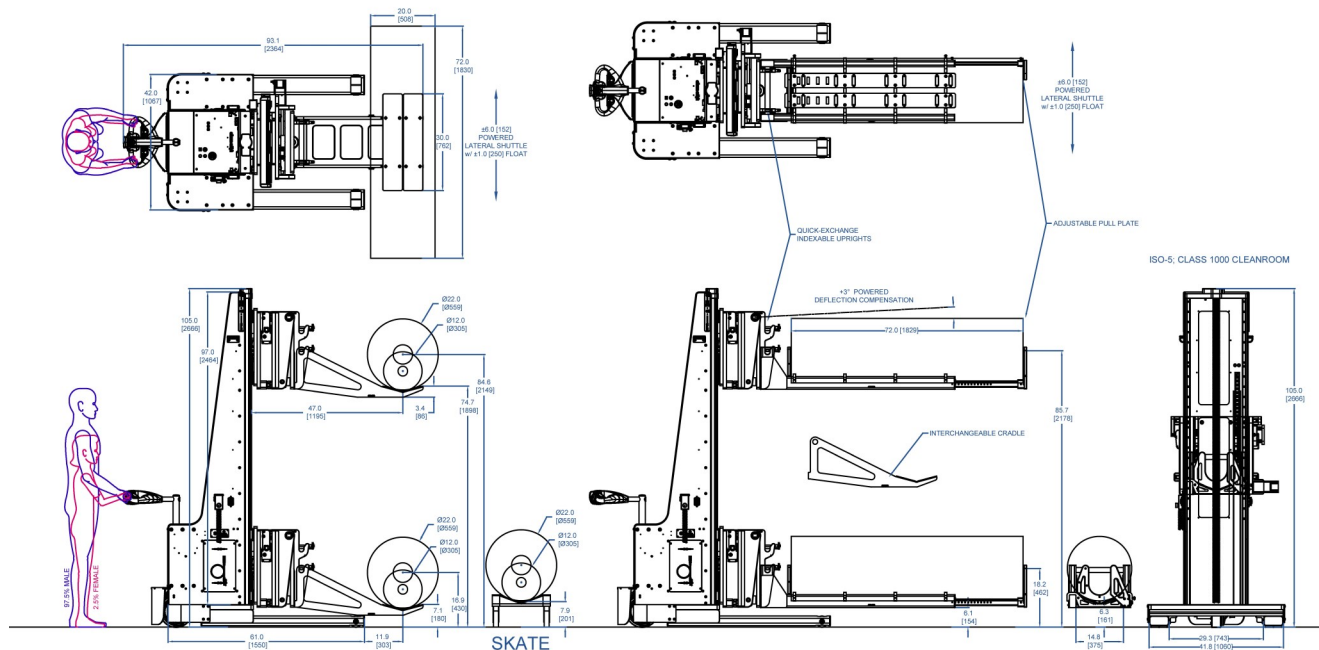

alum-a-lift

13941 Veterans Memorial Hwy
Winston, GA 30187 USA
+1 770 489 0328

GET STARTED AT ALUM-A-LIFT.COM