

FEATURED ALUM-A-LIFT POWERED HEIGHT-ADJUSTABLE WORK BENCH

PROJECT 31247



MODEL Custom Work Bench

FEATURING Self-deploying Ramp and Retention Feature, Cantilevered Platform, Dual Lifting Masts

HANDLING 400 lb. [181 kg] Assemblies

DETAILS This workbench was designed to provide technicians with an ergonomic work space for a wheeled assembly. The dual-mast structure of the workbench keeps all sides of the platform clear to allow access for technicians, and the work platform can be adjusted to any height (up to 48") at the touch of a button to provide the correct working height. When the platform is lowered to the floor, a ramp extends automatically to allow carts to be rolled onto the platform. When the platform is raised, the ramp folds down and a small lip folds up to help retain the cart.

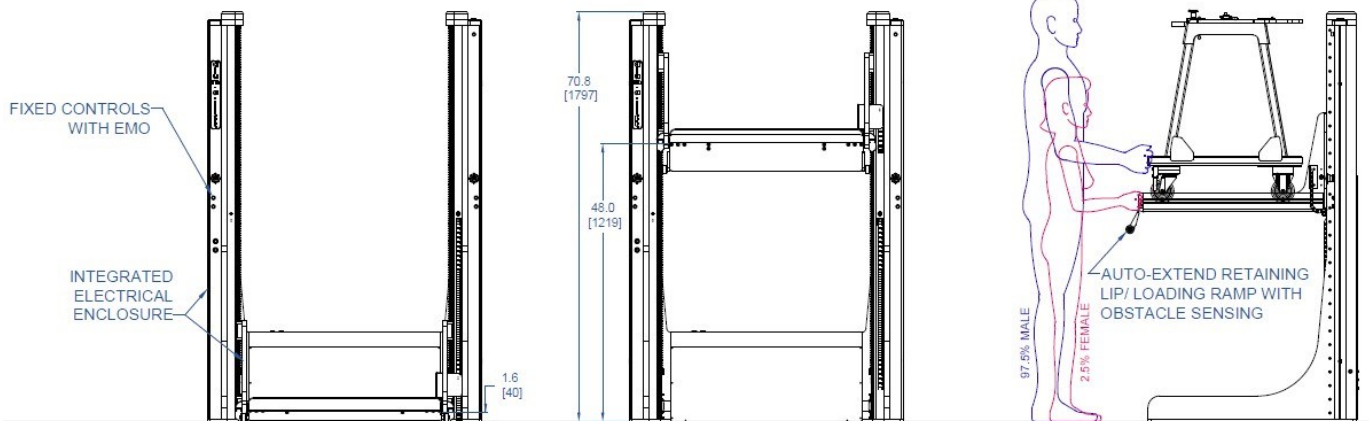
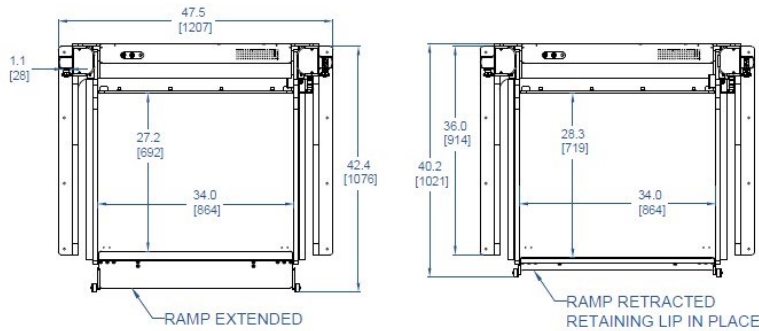

alum-a-lift

13941 Veterans Memorial Hwy
Winston, GA 30187 USA
+1 770 489 0328

GET STARTED AT ALUM-A-LIFT.COM