

# FEATURED ALUM-A-LIFT ROLL HANDLING LIFT WITH ROTATING CLAMPS

## PROJECT 31244

**MODEL** A1500CS-72

**FEATURING** Powered Clamp, Powered Trunion, Heavy Duty Casters, Safe-to-Lift Indicator Light, Adjustable Clamp Force Limiter

**HANDLING** 500 lb [227 kg] Rolls

**DETAILS** A wide variety of industries utilize rolls or packing material in the production process. Often times these rolls are too heavy to handle by hand and require more precise handling than a traditional forklift can offer. This Alum-a-Lift features powered clamp with powered side to side rotation. This ergonomic material handling tool enables an operator to maneuver heavy rolls in and out of equipment safely and efficiently.

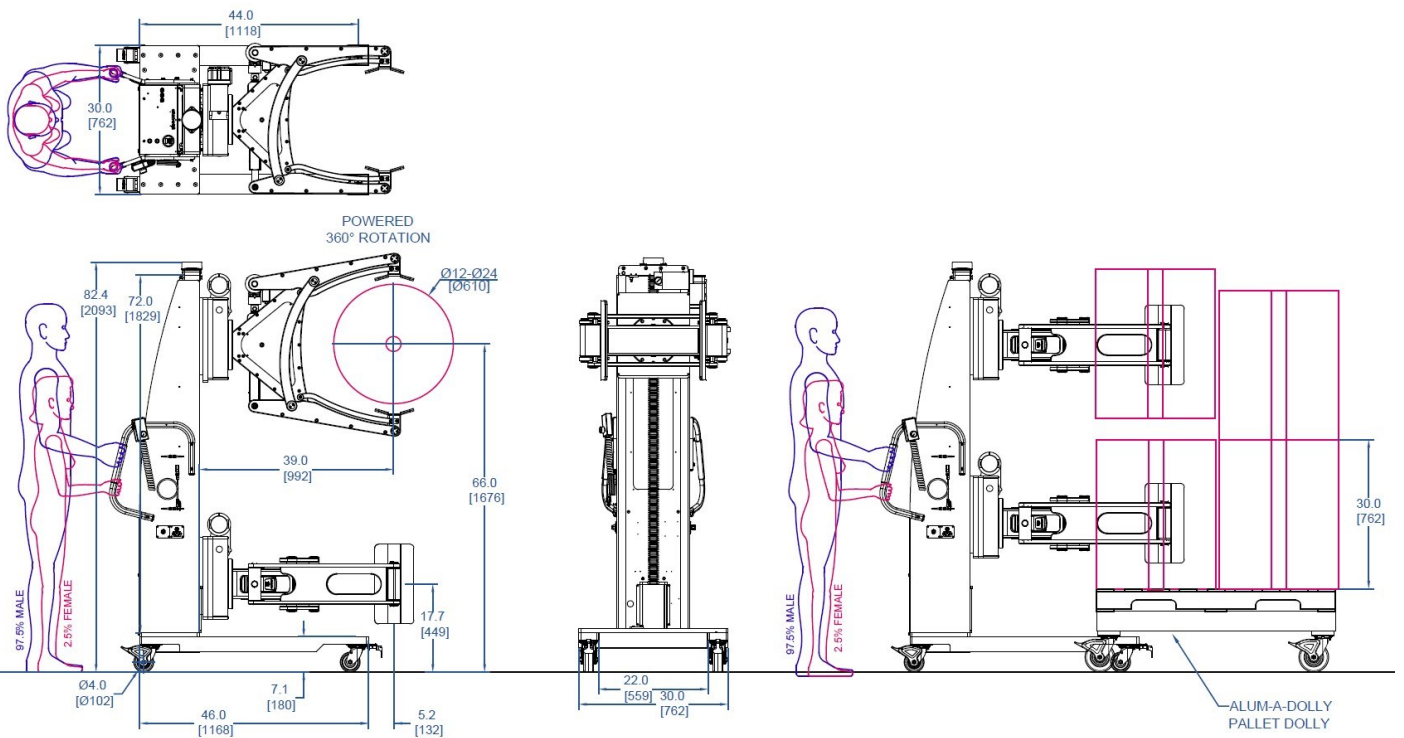

**alum-a-lift**

13941 Veterans Memorial Hwy  
Winston, GA 30187 USA  
+1 770 489 0328

GET STARTED AT [ALUM-A-LIFT.COM](http://ALUM-A-LIFT.COM)