

FEATURED ALUM-A-LIFT NARROW AISLE ROLL LIFTER WITH ROTATING CORE GRIPPER

PROJECT 33193



MODEL A800CS-72

FEATURING Roller Boom, Expanding Mandrel Nose, Powered Rotation, Travelling Limit Switch, Side-Push Handle, Quick Exchange Batteries

HANDLING 250 lb [113 kg] Rolls

DETAILS Many roll handling solutions exist to lift and rotate rolls onto winders and unwind shafts, but options become limited when space gets tight. This lift is ideal for legacy processes or cramped facilities when the narrow aisles in front of equipment are not much wider than the rolls themselves. This lift includes an expanding mandrel core gripper with an elongated core shaft and embedded rollers. With this lift, one operator can pick up a roll from by its core, rotate it 90°, and unload it onto a cantilevered mandrel.

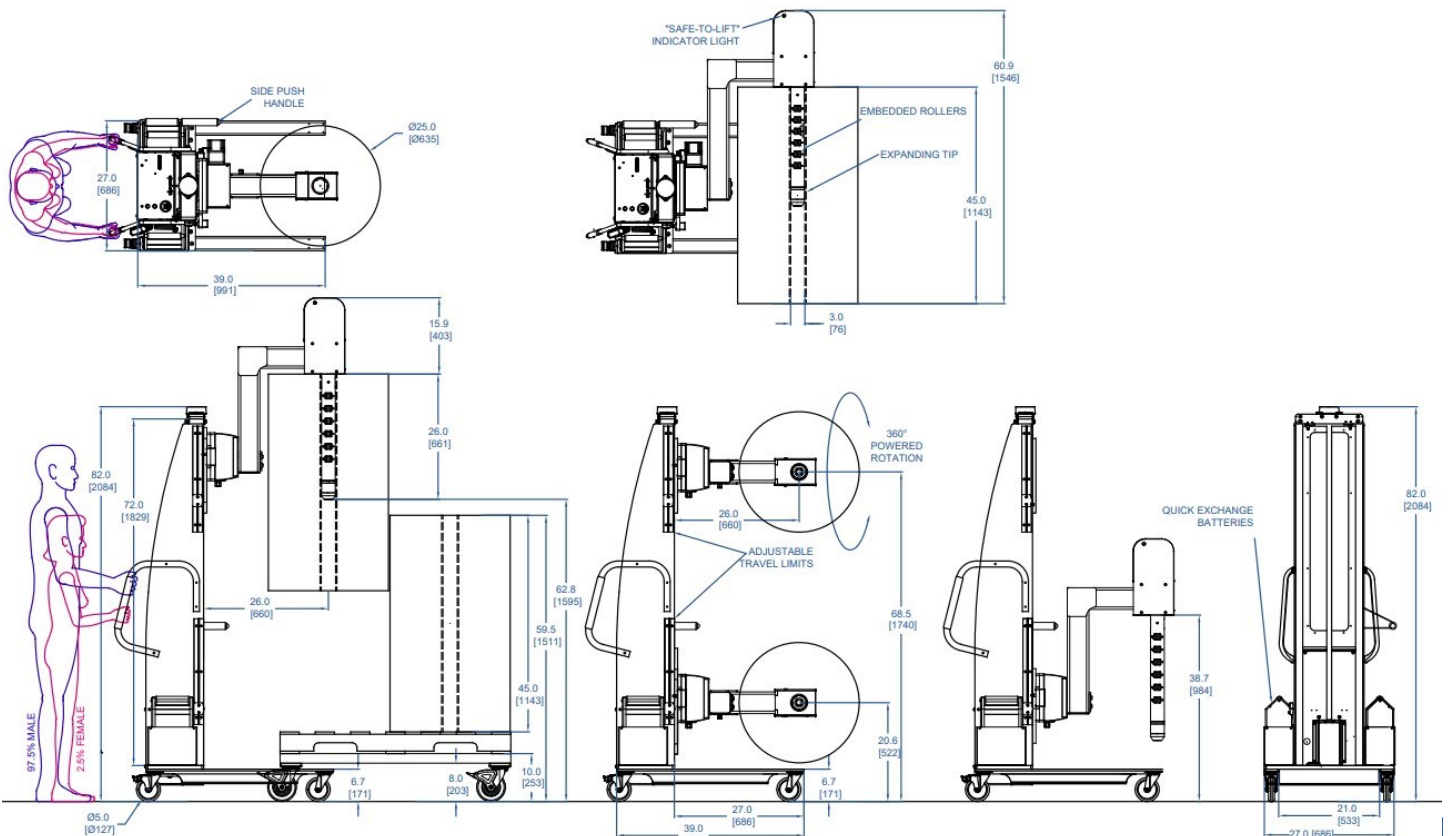

alum-a-lift

13941 Veterans Memorial Hwy
Winston, GA 30187 USA
+1 770 489 0328

GET STARTED AT ALUM-A-LIFT.COM