

# FEATURED ALUM-A-LIFT ROTATING POWERED GRIPPER WITH INTERCHANGEABLE JAWS

## PROJECT 33237



**MODEL** A800CSLR-68

**FEATURING** Rotating Powered Gripper, 90° Powered Front to Back Tilting, Interchangeable Jaws, Overload Safety Device, Sensing Hardware

**HANDLING** 220 lb [100 kg] Stacks of Precision Parts

**DETAILS** This custom lifting solution was designed to help a manufacturing company handle different precision parts needing to be stacked, compressed, taken to a banding machine where the stack is banded together, then taken to a measuring station with clearance restrictions and alignment requirements. Alum-a-Lift achieved all this by incorporating interchangeable jaws to accommodate the differences in hardware, sensing capabilities for aligning stacks with tooling, the ability to compress the stacks, interlocks to prevent incorrect operation, and a spring overload safety device in the event of an overload.

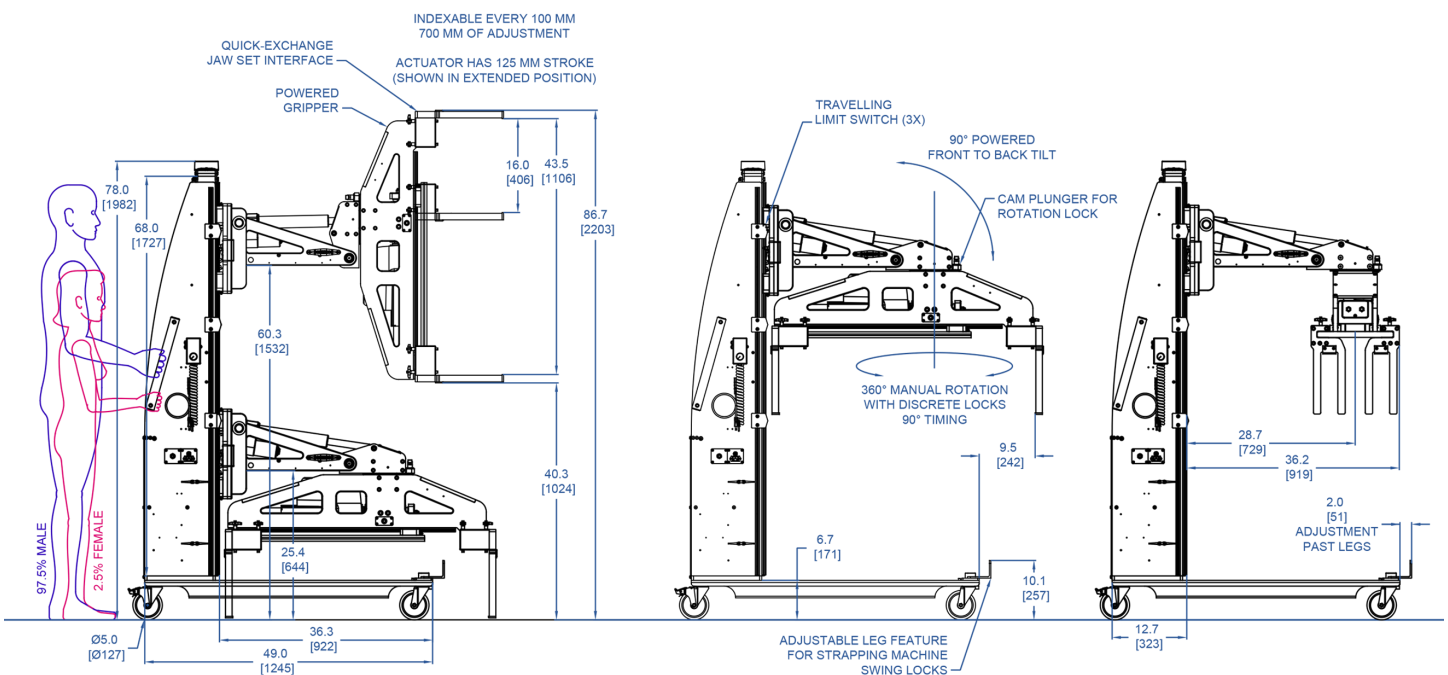

**alum-a-lift**

13941 Veterans Memorial Hwy  
Winston, GA 30187 USA  
+1 770 489 0328

GET STARTED AT [ALUM-A-LIFT.COM](http://ALUM-A-LIFT.COM)