

FEATURED ALUM-A-LIFT NARROW CLEANROOM LIFT WITH SWIVEL BOOM

PROJECT 35871



MODEL B350CRCS-72/10W

FEATURING 10" Wide Frame, Extending Legs with Floor Brakes, Class 100 (ISO 5) Cleanroom Compliant, Swivel Boom

HANDLING 350 lb [158 kg] Acceleration Tubes

DETAILS The footprint of this narrow cleanroom lift is optimized to conserve floor space in a class 100 (ISO 5) cleanroom environment. With a slim 10-inch wide frame, it easily fits between manufacturing machinery to service acceleration tubes. The legs can rotate outward 45 degrees and be locked in an open position for transport or closed when working enables precise alignment, which is essential for top performance of equipment.

Alum-a-Lift's design reduces particulate emissions to avoid contamination in the cleanroom and works seamlessly with the equipment, making it the ideal choice for efficiency and productivity.

CLASS 100 CR (ISO 5) RATED

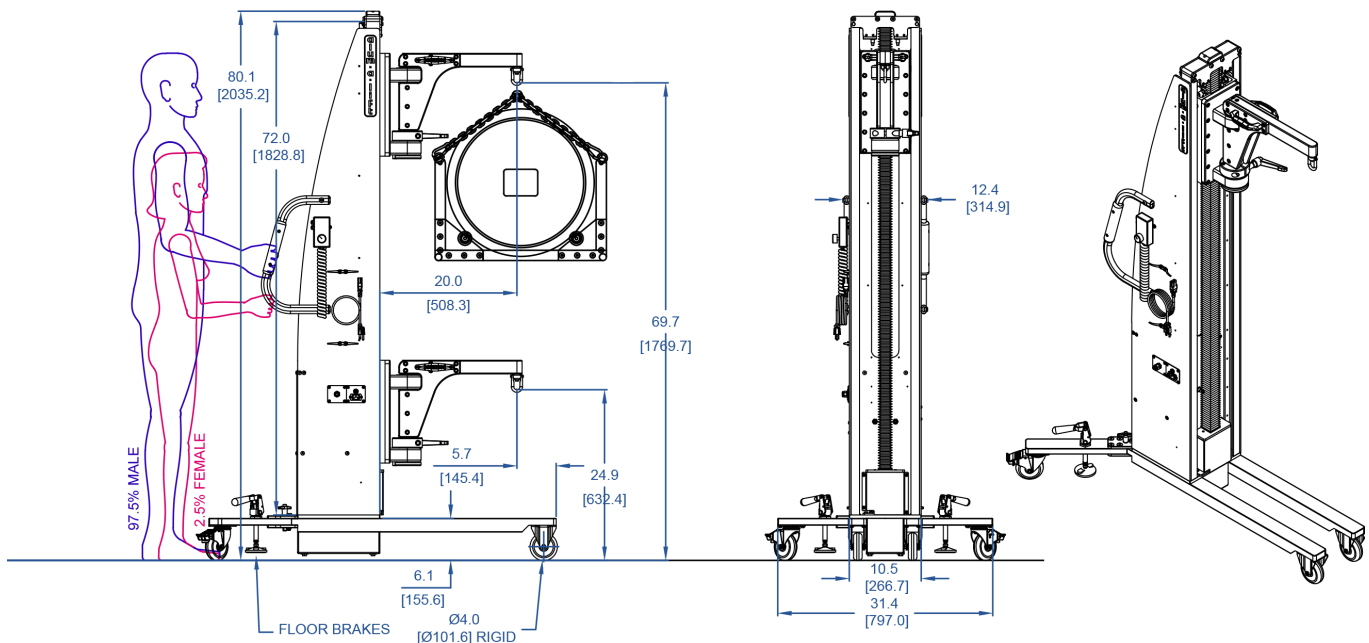

alum-a-lift

13941 Veterans Memorial Hwy
Winston, GA 30187 USA
+1 770 489 0328

GET STARTED AT ALUM-A-LIFT.COM