

FEATURED ALUM-A-LIFT RETAINING PLATFORM LIFT FOR MONEY HANDLERS

PROJECT 35073



MODEL B350CS-72

FEATURING Platform with Retaining Fence and Locking Pin, All-Electric Drivetrain

HANDLING 150 lb [68 kg] Money Handlers

DETAILS Money handlers (a.k.a. currency counters or bill counters) are machines designed to quickly and accurately count banknotes and are installed within a variety of businesses and organizations known for handling large amounts of cash. This model is too large for manual handling, making it difficult to maneuver when fully assembled.

Alum-a-Lift's widened, box-beam reinforced baseplate resists bending and twisting, while its wide-set legs easily straddle client equipment. The ergonomic design also minimizes operator injury risk.

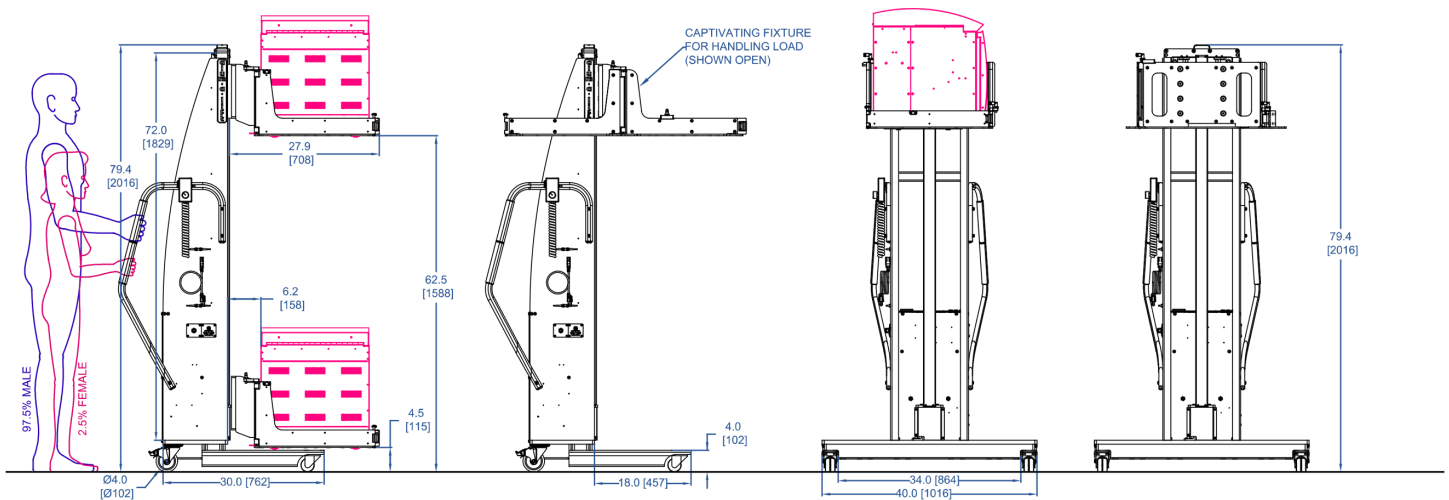

alum-a-lift

13941 Veterans Memorial Hwy
Winston, GA 30187 USA
+1 770 489 0328

GET STARTED AT ALUM-A-LIFT.COM